



POCKET ⚡ POWER™ 9000
Universal Power Charger



Operating Instructions

Contents

Introduction	1
Operating Instructions	2-5
Demonstrations	6-8
Storing/Handling/Cleaning	9
Safety Precautions	9-10
Specifications	10
FCC Compliance Statement	11-12
Limited Warranty	12-14
Contact Information	14

To contact us, email us at
support@halo2cloud.com
or call 888-907-6274



What's Included With Your HALO Pocket Power 9000

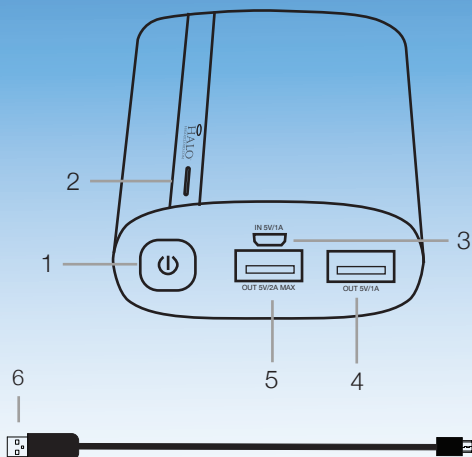

1. Power button (turn ON/OFF)
2. LED battery indicator lights
3. Micro USB input port (5V/1A)
4. Standard USB output port (5V/1A)
5. Standard USB output port (5V/2A)
6. Standard USB to Micro USB Cable

Included Items:





- HALO Pocket Power 9000
- Standard USB to Micro USB Cable
- Operating Instructions

Operating Instructions





Getting Started

Quickly press and release the power button to determine if your HALO charger is full. The LED battery indicator will display four solid blue lights when fully charged. Charge your HALO charger until all four LED lights on the front of your charger turn solid blue (no lights should be flashing).

Check Your HALO Charger's Battery Level

Indicator Lights	How To Read	Amount of Charge
	One solid light	0%-25%
	Two solid lights	26%-50%
	Three solid lights	51%-75%
	Four solid lights	76%-100%

Reading Your LED Battery Indicator While Charging Your HALO Charger

Indicator Lights	How To Read	Amount of Charge
	First light blinking	0%-25%
	First light solid, second light blinking	26%-50%
	First two lights solid, third light blinking	51%-75%
	First three lights solid, fourth blinking	76%-99%
	All four lights solid	100% fully charged

Turning your HALO Pocket Power 9000 ON/OFF

To turn on, press the power button, and the LED lights on the side of your HALO charger will illuminate. Press and hold the power button for three seconds to turn off. Your HALO charger is also equipped with an auto on/off feature. Your charger will automatically turn on and begin charging when an electronic device is plugged in and will automatically shut off after 30 seconds if not in use.

Charging your HALO Pocket Power 9000

To recharge your HALO charger, using the provided Standard USB to Micro USB cable, plug the Micro USB tip into the charger's 5V/1A Micro Input port. Next, connect the USB end of the Standard USB to Micro USB cable into the Standard USB port on your computer or into an AC wall adapter that accepts a Standard USB connection. Your HALO charger will automatically begin charging. Charge your HALO charger for a full six hours. See Demonstration 1 on Page 6 for more information.

Charging An Electronic Device Using 5V/1A Output Port

For personal electronic devices with a Micro USB port, plug the Micro USB tip of the Standard USB to Micro USB cable into your electronic device. Next, plug the Standard USB end of the Standard USB to Micro USB cable into your HALO charger's 5V/1A Output port. Your HALO charger is also compatible with the charging cable provided with your personal electronic device. To use, plug the Standard USB end of the cable into your HALO charger's 5V/1A USB output port.

Charging An Electronic Device Using 5V/2A Output Port

The 5V/2A port will charge the same devices as the 5V/1A port but at a faster speed. The 5V/2A port is recommended when charging tablets and other larger electronic devices. Repeat the steps above under “Charging An Electronic Device Using 5V/1A OUT Port” for Micro USB port devices, but instead, plug the Standard USB end of the Standard USB to Micro USB cable into your HALO charger’s 5V/2A OUT port. Your HALO charger is also compatible with the charging cable provided with your personal electronic device. To use, plug the Standard USB end of the cable into your HALO charger’s 5V/1A USB output port.

Charging Two Electronic Devices

You can simultaneously charge two devices by using both the 5V/1A Output port and the 5V/2A Output port on your HALO charger. You will need to use both the provided Standard USB to Micro USB cable and the cable that came with your personal electronic device to use both Output ports at the same time.

Intelligent Recognition

Your HALO charger is programmed with an intelligent recognition system to achieve higher compatibility for charging different mobile phones. If it does not charge when connected to your mobile phone, please restart your HALO charger.

Compatible with:

Mobile phones, Tablets, PSP, NDS, MP3, MP4, MP5, Bluetooth, GPS, Cameras and more.



MOBILE PHONES



TABLETS



CAMERAS



GPS



GAMING



MP3

Demonstration 1

Charging your *HALO Pocket Power 9000* from a computer USB port.

Note: you can also plug the Standard USB end of the Standard USB to Micro USB cable into an AC wall adapter that accepts Standard USB connection.

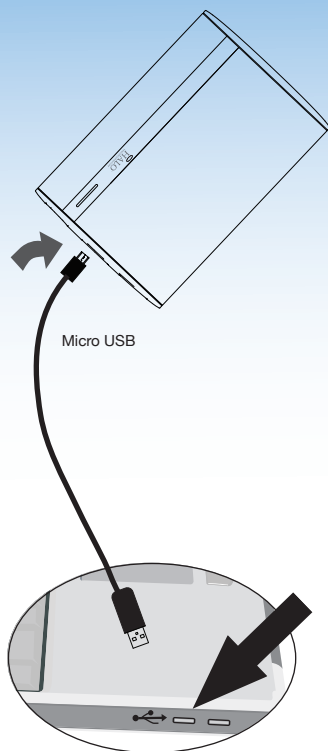

Demonstration 2

Charging Micro USB electronic devices using the 5V/1A Output port (#4 on illustration) and the Micro USB tip of the Standard USB to Micro USB cable.

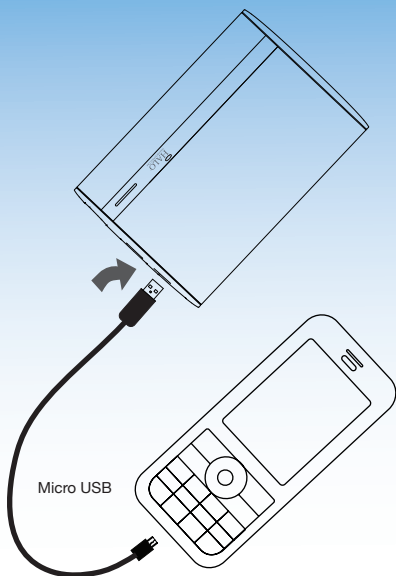

Compatible with:

Samsung Galaxy S4, S5
Samsung Galaxy SIII
Samsung Galaxy Note II
Blackberry Z10
+ many additional models

Demonstration 3

Charging Micro USB electronic devices using the 5V/2A Output port (#5 on illustration) and the Micro USB tip of the Standard USB to Micro USB cable.

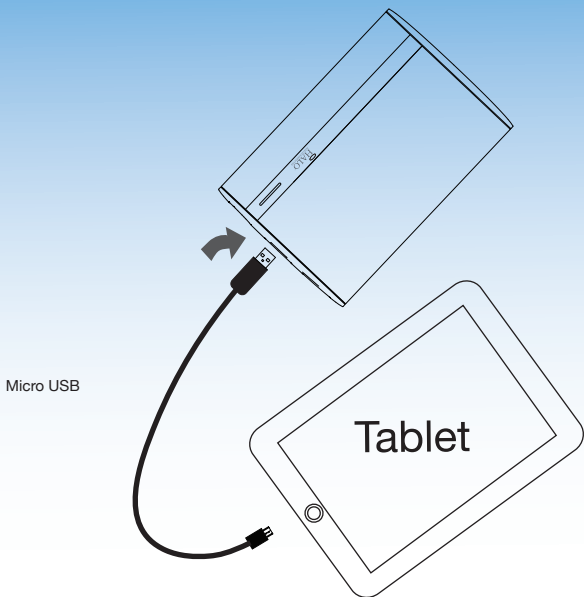

Compatible with:

Kindle Fire
Google Nexus Tablet
Blackberry Play Book
+ many additional models

When charging the following devices, please use cord provided with the device:

Nook Color
Nook HD
Samsung Galaxy Tab 2, 3

Storing/Handling/Cleaning

- Do not get your HALO charger wet or store in extreme temperature conditions.
- Do not disassemble or attempt to repair your HALO charger yourself.
- Use a soft cloth with soap to clean the exterior of your HALO charger. Do not use liquid detergent or chemicals of any kind on your HALO charger.

Safety Precautions

- Your HALO charger has been designed and manufactured to ensure personal safety. Please read the following carefully before using. Incorrect operation or incompatibility with your personal electronic device may result in reduced battery performance or damage.
- Carefully read the operating instructions, and use your HALO charger correctly.
- Caution: The lithium-ion rechargeable battery used in this charging device may present a risk of fire or chemical burn if mistreated. Do not disassemble, expose to heat above 212°F (100°C) or incinerate.
- Misusing or incorrectly connecting your HALO charger may cause electric shock to users and damage equipment. Your HALO charger may become warm under extended high power operation. During operation, keep your HALO charger away from materials that may be affected by these temperatures.
- When used correctly, lithium-ion rechargeable batteries provide a safe and dependable source of portable power. However, if they are misused or abused, this may result in leakage, burns, fire or explosion, causing personal injury or damage to other devices.

- Do not disassemble your HALO charger. There are no user-serviceable parts inside. Incorrect reassembly may result in shock or fire hazard.
- Do not drop or subject to strong impacts. Do not operate your HALO charger if it has received a sharp blow, or has otherwise been damaged in any way.
- Do not expose your HALO charger to moisture, water, rain, or snow.
- Do not insert any object into the ports or openings of your HALO charger.
- Never leave your HALO charger unattended while charging.
- There is a risk of the batteries exploding, overheating, or igniting. Do not disassemble, modify, heat or short-circuit the batteries. Do not place in fire or leave in hot places. Do not expose to direct sunlight.
- Only charge your HALO charger by the specified method with the specified USB cable.
- In the unlikely event of leakage or explosion use sand or a chemical fire extinguisher.
- Batteries should be recycled or disposed of as per state and local guidelines.

Specifications

Battery Cell: Samsung 18650 battery

Capacity: 9000 mAh

Micro USB Input: 5V/1A

USB Output: 5V/2A Max, 5V/1A

Dimensions: 3.86"x 2.49"x 0.98" (98.2 x 63.4 x 25mm)

FCC Compliance Statement

This device complies with Part 15 of the FCC Rules.

Operation is subject to the following two conditions:

- This device may not cause harmful interference, and
- This device must accept any interference received, including interference that may cause undesired operation.

15.21

You are cautioned that changes or modifications not expressly approved by the party responsible for compliance could void the user's authority to operate the equipment.

15.105(b)

This equipment has been tested and found to comply with the limits for Class B digital devices, pursuant to Part 15 of the FCC rules. These limits are designed to provide reasonable protection against harmful interference in a residential installation. This equipment generates, uses, and can radiate radio frequency energy and, if not installed and used in accordance with the instructions, may cause harmful interference to radio communications. However, there is no guarantee that interference will not occur in a particular installation. If this equipment does cause harmful interference to radio or television reception, which can be determined by turning the equipment off and on, the user is encouraged to try to correct the interference by one or more of the following measures:

- Reorient or relocate the receiving antenna.
- Increase the separation between the equipment and receiver.
- Connect the equipment into an outlet on a circuit different from that to which the receiver is connected.

- Increase the separation between the equipment and receiver.
- Connect the equipment into an outlet on a circuit different from that to which the receiver is connected.
- Consult the dealer or an experienced radio/TV technician for help.

Limited Warranty

What does this limited warranty cover and how long is the coverage?

Halo2Cloud, LLC (“HALO”) warrants its products to be free from defects in materials and workmanship under normal use and service for a period of one (1) year beginning on the date you purchase the product.

What is not covered by this limited warranty?

This Limited Warranty does not cover defects or damage due to: (1) accidents, acts of God, misuse, abuse, abnormal use, abnormal conditions, improper storage, or exposure to liquid or moisture, (2) unusual or abnormal physical force or impact, including dropping of the product, (3) connection of the product to improper voltage supply, or (4) attempted repair or modification by anyone other than HALO or a facility authorized by HALO.

What are HALO’s obligations under this limited warranty?

Provided that you comply with the conditions of this Limited Warranty, during the duration of this Limited Warranty HALO will repair or replace the product, at its sole option, without charge. When repairing or replacing a product, HALO may, at its sole option, repair or replace

the product with new, used, rebuilt or reconditioned parts or products. HALO will warrant any product that is repaired or replaced under this Limited Warranty for a period equal to the remaining time period under the original Limited Warranty or ninety (90) days, whichever is longer.

How do you get service?

To obtain service under this Limited Warranty, you must (1) within ninety (90) days of the purchase of the product, register you product at www.halo2cloud.com, (2) obtain a return materials authorization number (RMA) by contacting HALO at (888) 907-6274, and (3) return the product to HALO at 148 Eastern Boulevard, Glastonbury, Connecticut 06033, Attention: Returns Department, together with your RMA and the sales receipt or similar proof of sale showing the original date of purchase of the product and the seller's name and address. If HALO determines that your product is not covered by this Limited Warranty, HALO will notify you of such determination and you may decide whether to have HALO return the product to you or attempt to repair the product. In this case, you will be required to pay all shipping and labor charges for the repair or return of your product, as applicable.

What are the limits of HALO's Liability?

This Limited Warranty sets forth the full scope of HALO's obligations and liabilities with respect to the product. All implied warranties, including, without limitation, implied warranties of merchantability and fitness for a particular purpose, are limited to the duration of this Limited Warranty. In no event shall HALO be liable for any

incidental, special, consequential or punitive damages or any damages or losses of or to electronic equipment or products that are used with any of HALO's products.

How does state law relate to this limited warranty?

Some states do not allow limitation on how long an implied warranty lasts or the disclaimer or limitation of incidental or consequential damages. Therefore, some or all of the disclaimers and limitations above may not apply to you.

To contact us, email us at
support@halo2cloud.com
or call 888-907-6274

Halo International SEZC Ltd.
HSBC House
68 West Bay Road
Grand Cayman, Cayman Island KY-1003

The HALO cloud logo is
a registered trademark of
HALO2CLOUD, LLC

Designed by HALO International SEZC Ltd.

Patent Pending Made in China

The material used on this item is a Man Made Material





HALO™
HALO2CLOUD.COM